

## CLS 400mm BOX-TRUSS

TR115 TR116 TR117 TR118 TR131 TR132 TR181

### FEATURES:

CLS 400mm BOX TRUSS - THE SMALLER BROTHER TO OUR FLAGSHIP 500mm SERIES - IS THE ANSWER WHEN YOU NEED TORSIONAL RIGIDITY OVER A WIDE-SPAN. MADE USING THE SAME SIZE MATERIALS AS CLS 500mm BOX, IT'S A REAL HEAVYWEIGHT. FOR TOURING SHOWS WITH LARGE MOVING FIXTURES BUT A PREMIUM ON TRUCK SPACE - 400mm BOX IS THE OBVIOUS CHOICE.

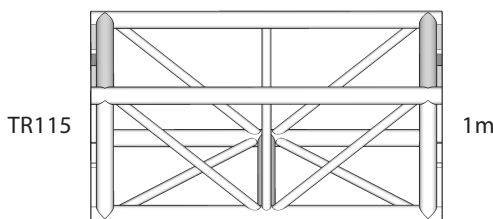
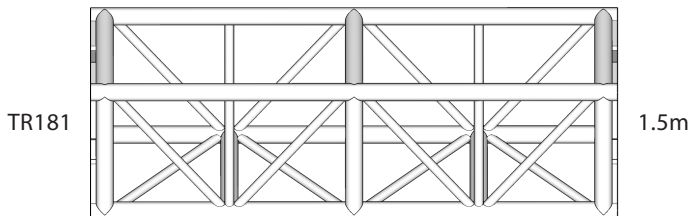
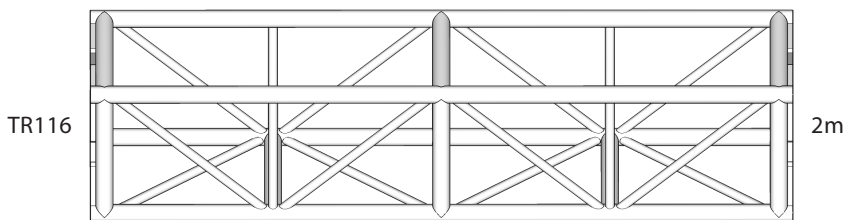
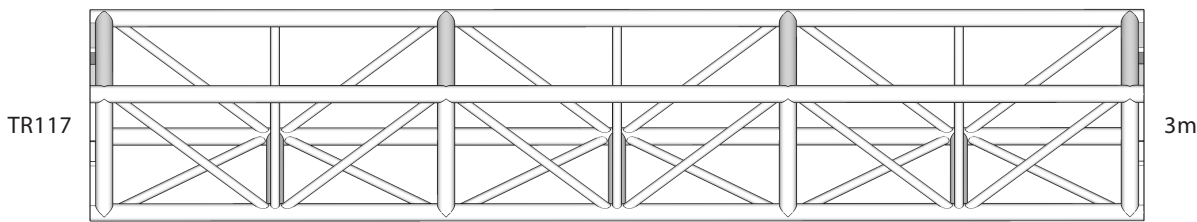

4m, 5m & 6m ALSO AVAILABLE (FOR SALE ONLY) - SEE SALES PRICE-LIST.

CUSTOM SIZES (ACCURATE TO 1mm) AVAILABLE ON REQUEST.

NOT AVAILABLE FOR HIRE - USE 500mm BOX OR GROUND SUPPORT TOWERS INSTEAD.

GROUND SUPPORT TOWERS SHARE SAME DESIGN AND GEOMETRY BUT WITH ADDITIONAL 48.4mm RUNGS ON THE LADDER-SIDE.

SPAN (METRES)	MAXIMUM POINT LOAD (Kg)	MAXIMUM UNIFORMLY DISTRIBUTED LOAD (Kg/m)
3	5053	2405
6	1077	359
9	675	150
12	462	76
15	329	43
18	222	24

NOTE: • RATINGS VALID ONLY INDOORS  
 E.G. RATINGS DO NOT APPLY IN WIND  
 • ABOVE RATINGS IN ADDITION TO NET WEIGHT OF SPAN (BASED ON 3M SECTIONS)

©2008 CLSA PTY. LTD.

63-65 KINGSWAY, SOUTHBANK VIC 3006  
 ph 03 9682 6111 fax 03 9682 6777

info@clsa.com.au

60 EPSOM ROAD, ROSEBERY NSW 2018  
 ph 02 9697 2500 fax 02 9697 2522

ABN 14 005 422 319



CONCERT LIGHTING SYSTEMS AUSTRALIA

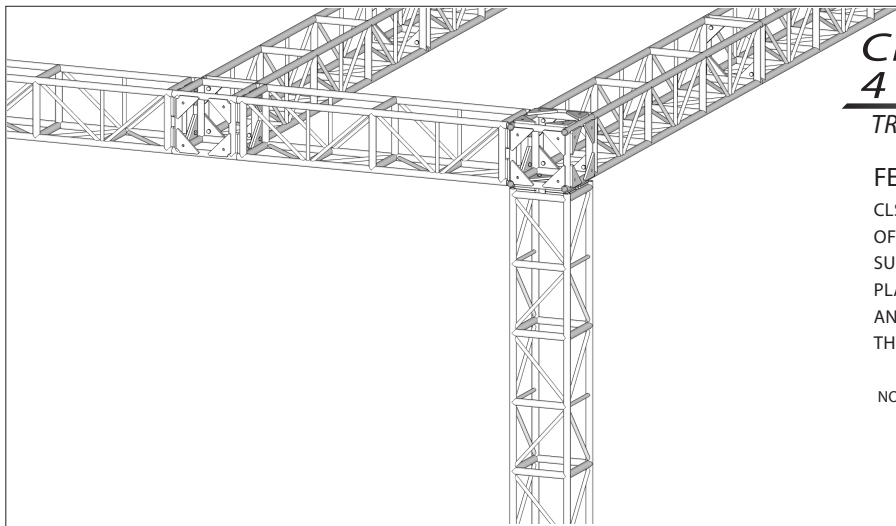

# CLS 400mm BOX 4 & 6-WAY JOINERS

TR135 TR214

## FEATURES:

CLS 400mm BOX-TRUSS JOINING CUBES ARE THE STANDARD MEANS OF BUILDING HEAVY-DUTY MOTHER-GRIDS OR CRANE-ERECTED GROUND SUPPORT STRUCTURES. THEY FEATURE THE SAME 16mm ALLOY GUSSET-PLATES FOUND THROUGHOUT ALL CLS 400 & 500mm BOX PRODUCTS, AND AS SUCH PROVIDE THE CONSISTENT APPEARANCE AND RIGIDITY THE PRODUCTION INDUSTRY IN AUSTRALIA HAS COME TO EXPECT.

NOTE: • IN A MOTHER-GRID - USE CUBES AND JOINING SECTIONS TO SHARE LOAD ACROSS HOISTS AND AID LATERAL RIGIDITY. DO NOT CREATE A MOTHER-GRID TO REDUCE THE OVERALL NUMBER OF HOISTS REQUIRED - ALWAYS OVER-SPECIFY RIGGING, PICKUP EACH HEAVY RUN INDEPENDENTLY, AND FACTOR IN SELF-WEIGHT OF TRUSS & RIGGING.

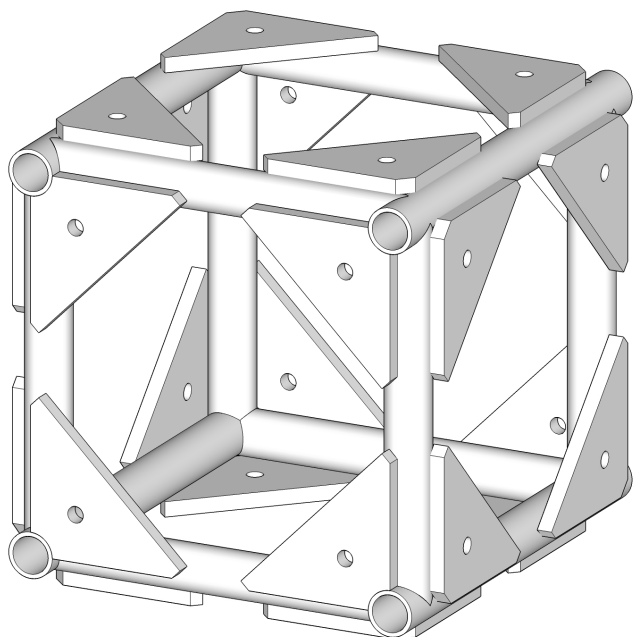
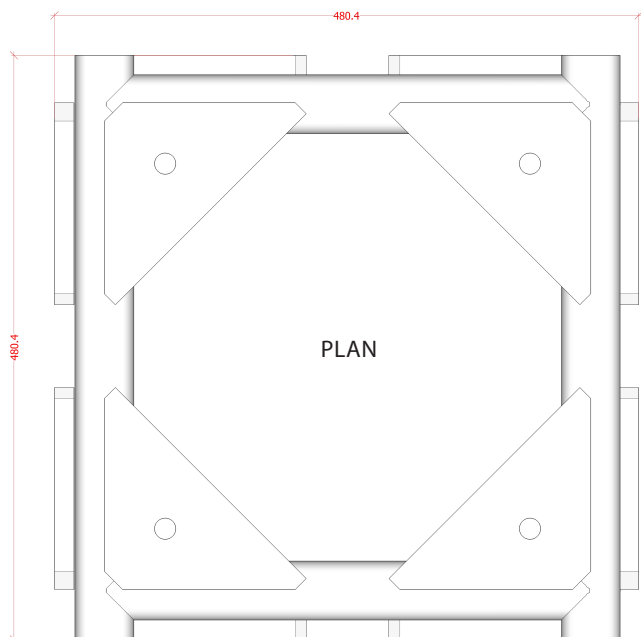

ISO - TR135 - 6-WAY

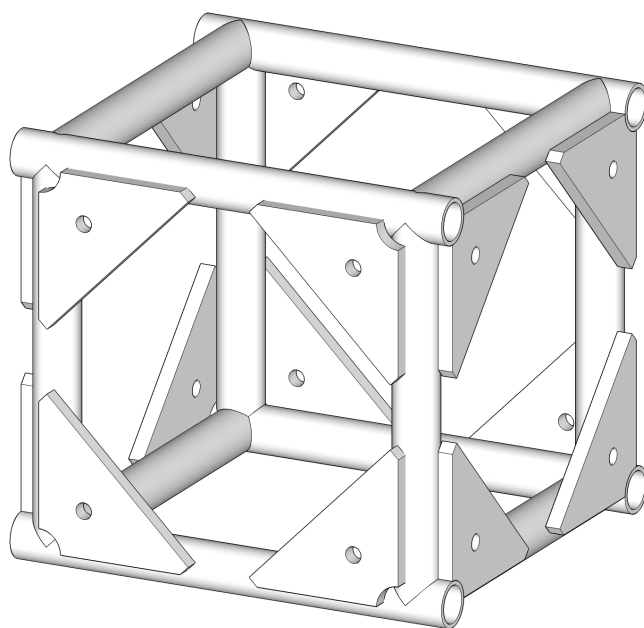

ISO - TR214 - 4-WAY

©2008 CLSA PTY. LTD.

63-65 KINGSWAY, SOUTHBANK VIC 3006  
ph 03 9682 6111 fax 03 9682 6777

info@clsa.com.au

60 EPSOM ROAD, ROSEBERY NSW 2018  
ph 02 9697 2500 fax 02 9697 2522

ABN 14 005 422 319



CONCERT LIGHTING SYSTEMS AUSTRALIA

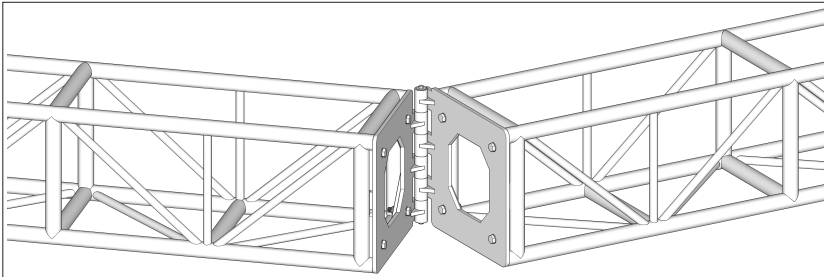

# CLS 400mm BOX-TRUSS HINGE-JOINER

TR213

## FEATURES:

CLS 400mm HINGE-JOINERS OFFER A SOLID-MEANS OF CONNECTING ADJACENT RUNS OF TRUSS. MADE FROM 12mm ALLOY PLATE WITH GUSSET-REINFORCED HINGES, THE HINGE-JOINER IS IDEAL FOR CLOSING A TRIANGLE OR TO KEEP A SEAMLESS SHAPE FOR 'IN THE ROUND' LIGHTING & DRAPE SUPPORT.

NOTE: • MUST BE SUPPORTED AT EACH END - NEVER ALLOW HINGED SECTION TO SWING FREELY  
• SPECIAL ATTENTION MUST BE GIVEN TO WEIGHT-DISTRIBUTION & SUPPORT WHEN USING HINGE PIECES

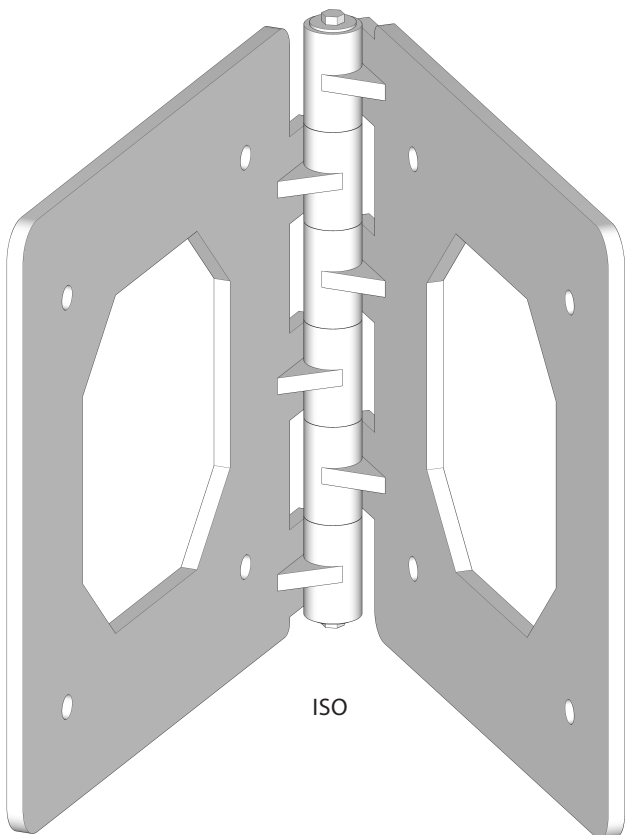
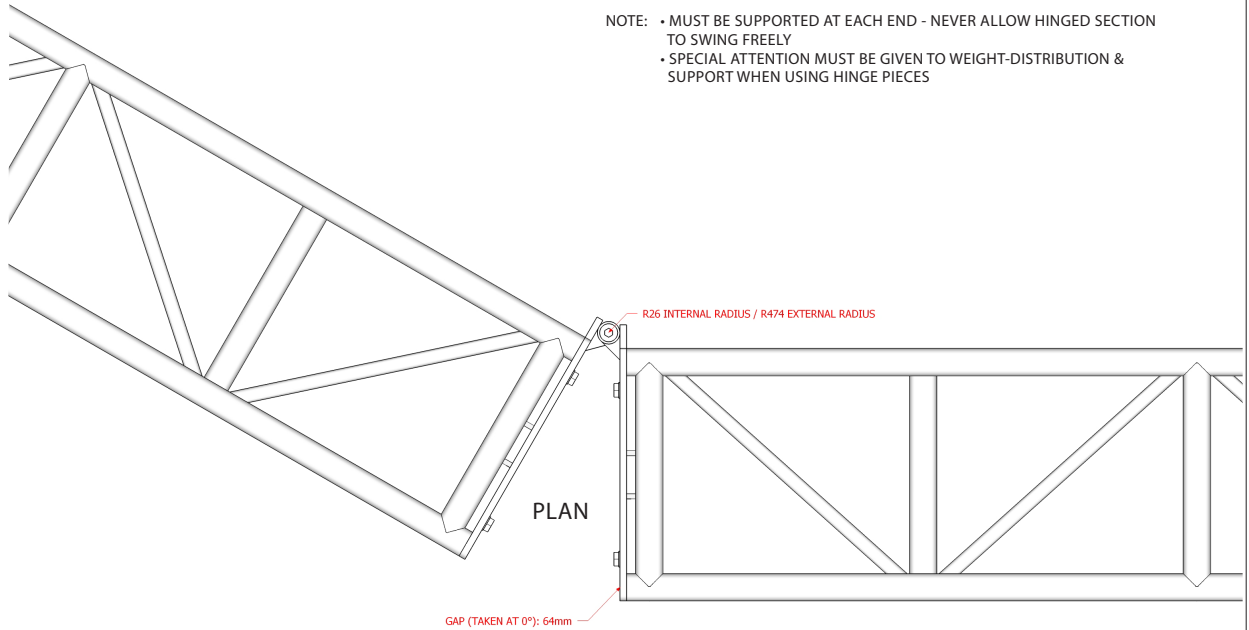

ISO

©2008 CLSA PTY. LTD.

63-65 KINGSWAY, SOUTHBANK VIC 3006  
ph 03 9682 6111 fax 03 9682 6777

info@clsa.com.au

60 EPSOM ROAD, ROSEBERY NSW 2018  
ph 02 9697 2500 fax 02 9697 2522

ABN 14 005 422 319



CONCERT LIGHTING SYSTEMS AUSTRALIA

# CLS 400mm BOX-TRUSS SUSPENSION BRACKET

TR112

## FEATURES:

CLS 400mm SUSPENSION BRACKETS ARE A TIDY AND EFFECTIVE MEANS OF HANGING 400mm BOX TRUSS PRODUCTS. IDEAL FOR INSTALLATIONS WHERE BALANCE IS ESSENTIAL OR A QUICK MEANS OF RIGGING AND DE-RIGGING IS REQUIRED.

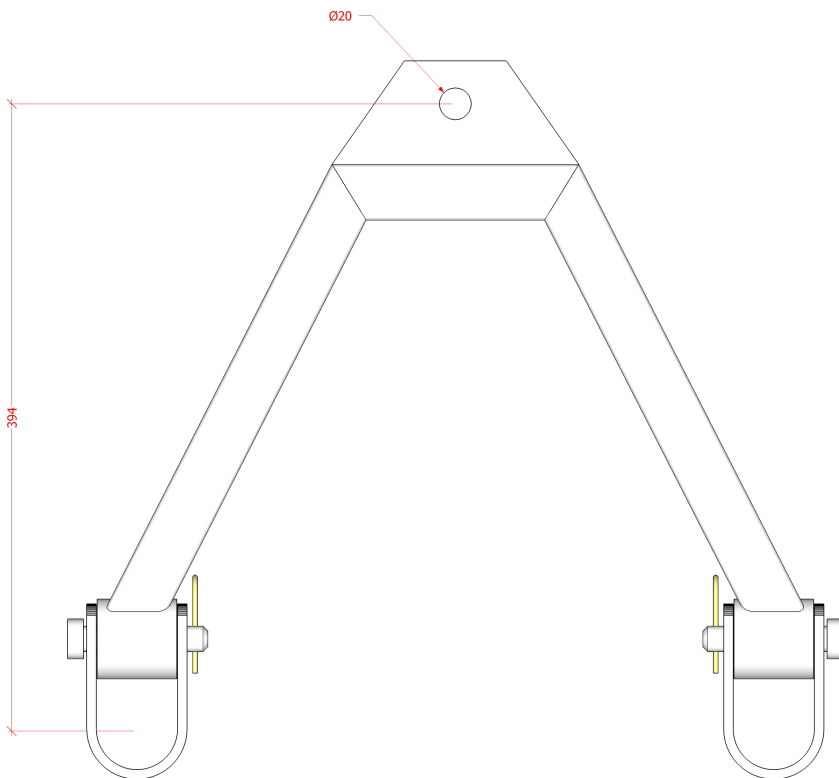
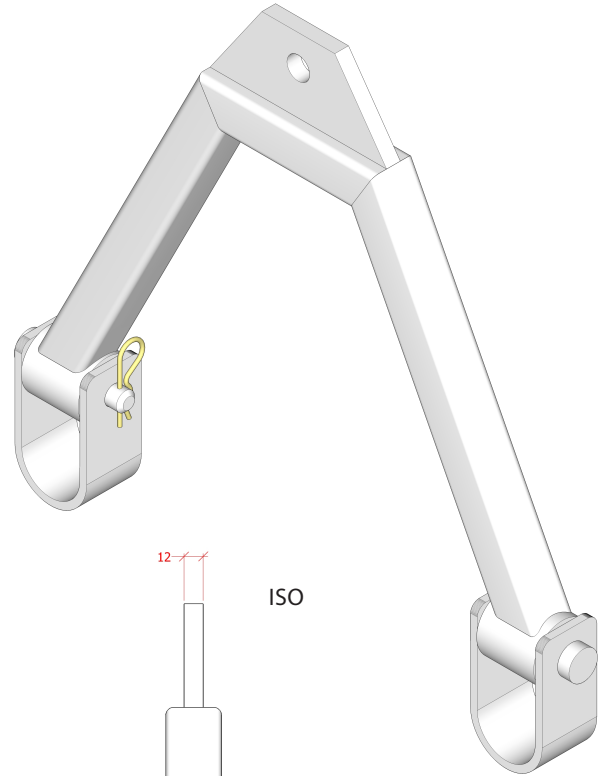
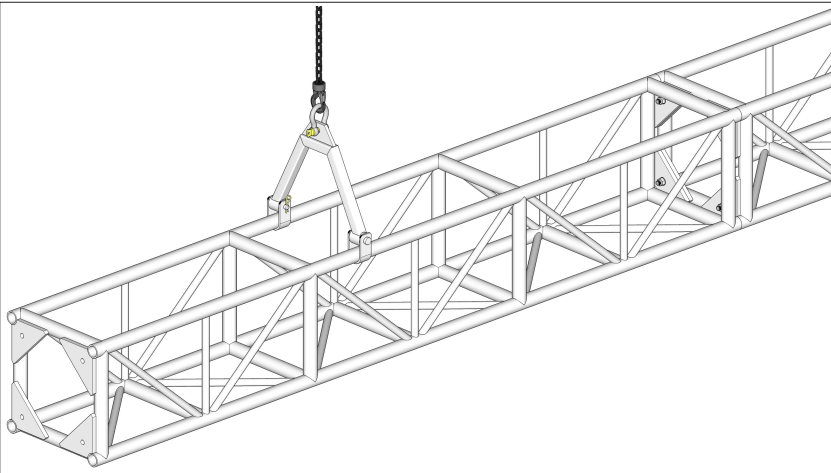

FRONT

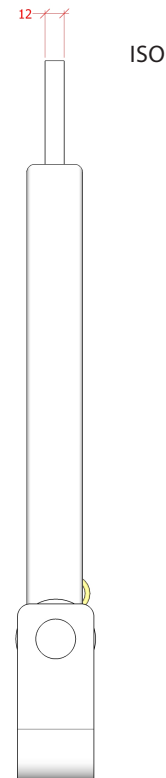

SIDE

©2008 CLSA PTY. LTD.

63-65 KINGSWAY, SOUTHBANK VIC 3006  
ph 03 9682 6111 fax 03 9682 6777

info@clsa.com.au

60 EPSOM ROAD, ROSEBERY NSW 2018  
ph 02 9697 2500 fax 02 9697 2522

ABN 14 005 422 319



CONCERT LIGHTING SYSTEMS AUSTRALIA